



# BOSCH

Invented for life

## Bosch Water Source Heat Pump

### LV Models

The option-rich, water-to-air LV offers one of the smallest cabinets in the industry, making it a great choice for replacement and new construction projects.



# Compact, Efficient & Option-Rich

## Meet the Bosch LV

The LV Model comes equipped with a compact cabinet designed to fit most commercial replacement projects. This option-rich, single-stage product offering is available in ½ to 6 ton size range and meets or exceeds ASHRAE 90.1 efficiency standards. Outfitted with the latest in compressor, blower motor and heat transfer technologies, this product performs extremely well in both water loop and geothermal applications.

### Quiet Operation

The LV Model comes standard with a unique sound package designed to eliminate vibration transmission to the cabinet and reduce unwanted noise in the occupied space. The product is designed with blower wheels that help keep discharge air noise to a minimum.

### Cabinet Configuration Flexibility

The LV horizontal cabinets come standard with blower systems that are easily reconfigured on the job site. The blower discharge arrangement can be changed from end to straight through discharge in only a matter of minutes.

### Environmentally Friendly

These highly efficient units not only reduce your operating cost, but play their part in reducing carbon dioxide emissions, a leading cause of global warming.

### Quality & Reliability

Rigorous factory testing virtually assures hassle free operation from the start, while over 40 years of experience in designing heat pumps for commercial applications are your assurance of a state of the art quality product. Our ISO 9001-2008 and ISO 14001-2004 certified facilities provide consistent quality in every unit we build.



## Features

- ▶ Galvanized Steel Cabinet
- ▶ Stainless Steel Drain Pan
- ▶ Floating Base Pan
- ▶ PSC Blower Motor
- ▶ Copper Coaxial Heat Exchanger
- ▶ Inlet Blower-Ring
- ▶ Unit Protection Module (UPM)

## Optional Features

- ▶ DuoGuard™ Air Coil
- ▶ Hot Gas Reheat (on/off)
- ▶ Hot Gas Bypass
- ▶ 40VA, 50VA, 75VA, 100VA Transformers
- ▶ Cupro-nickel Coaxial Heat Exchanger
- ▶ DDC Controls
- ▶ Fiberglass Insulation with Compressor Sound Blanket
- ▶ Waterside Economizer (available on sizes 048, 060, 070)
- ▶ Closed-Cell Foam Insulation & Compressor Sound Blanket
- ▶ Internally Mounted 2-way Motorized Water Valve
- ▶ Externally Mounted Pump Package
- ▶ Internal Auto-flow Regulator
- ▶ Phase Protection Module (for 3-phase unit)
- ▶ Constant Torque or Constant Airflow ECM Motors
- ▶ 2" MERV-8 or MERV-13 Filters w/ 2" 4-sided Rack

## Options Designed for any Application

### 2-Way Motorized Water Valves

Opening only on a call for heating or cooling, this option helps to reduce energy usage from the primary loop pumps.

### Hot Gas Reheat Coil

During the dehumidification process, the hot gas reheat coil prevents over-cooling of the occupied space and improves indoor air quality and comfort.

### Air Coil Protection

The LV's copper tube tin-plating and polyester-polymer-coated aluminum fins pass 1000 hours of ASTM B117 salt spray testing. These protective coatings offer the best protection against adverse return air conditions.

### Cupro-Nickel Coaxial Heat Exchangers

When water quality is in question, cupro-nickel alloy is highly resistant to corrosion in seawater or other environments that could threaten the life of the heat exchanger.





## Technical Specifications

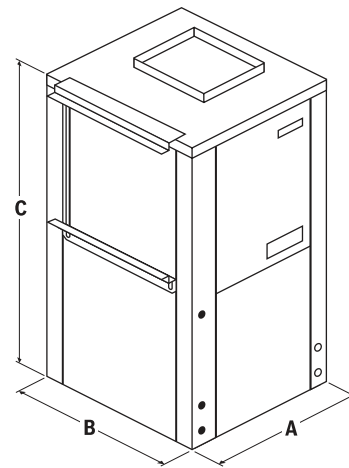
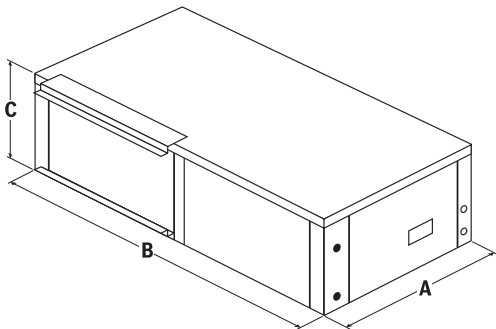

Horizontal Cabinet		Cabinet Dimensional Data		
		A (Width)	B (Depth)	C (Height)
007 - 012	in	19.0	33.0	11.5
	cm	48.3	83.8	29.2
015-018	in	22.0	43.0	17.0
	cm	55.9	109.2	43.2
024-030	in	22.0	43.0	18.0
	cm	55.9	109.2	43.2
036, 042	in	22.0	54.5	19.0
	cm	55.9	138.4	48.3
048 - 060	in	25.0	54.5	21.0
	cm	63.5	138.4	53.3
070	in	25.0	65.0	21.0
	cm	63.5	165.1	53.3

Vertical Cabinet		Cabinet Dimensional Data		
		A (Width)	B (Depth)	C (Height)
007 - 012	in	19.0	19.0	24.3
	cm	48.3	48.3	61.6
015 - 018	in	21.5	21.5	32.3
	cm	54.6	54.6	81.9
024, 030, 041	in	21.5	21.5	39.3
	cm	54.6	54.6	99.7
036, 042	in	21.5	26.0	44.3
	cm	54.6	66.0	109.9
048 - 060	in	24.0	32.5	45.3
	cm	61.0	82.6	114.9
070	in	26.0	33.3	58.3
	cm	66.0	84.5	148.0



Model	AHRI/ANSI 13256-1 Performance Data							
	Entering Water Temperatures							
	86 °F		68 °F		77 °F		32 °F	
	Water Loop				Ground Loop			
	Capacity and Efficiency Data - PSC Motor (Standard)							
	Cooling Capacity (WLHP)	EER (WLHP)	Heating Capacity (WLHP)	COP (WLHP)	Cooling Capacity (GLHP)	EER (GLHP)	Heating Capacity (GLHP)	COP (GLHP)
LV007	6,100	13.20	7,800	5.10	6,800	15.10	4,900	3.40
LV009	8,200	12.40	9,900	4.70	NA			
LV012	10,900	12.20	13,000	4.30	11,800	14.10	8,700	3.20
LV015	14,200	12.80	16,100	4.40	14,200	14.60	11,300	3.30
LV018	18,200	14.10	20,200	4.60	19,200	16.15	14,300	3.50
LV024	24,300	14.20	27,400	5.00	25,400	16.90	18,100	3.55
LV030	28,200	13.40	32,600	4.70	29,500	15.60	21,500	3.40
LV036	36,900	14.30	38,800	4.65	38,500	16.65	27,100	3.55
LV041	36,000	14.15	39,100	4.45	37,400	16.20	27,400	3.30
LV042	39,600	13.65	42,800	4.45	41,200	15.90	30,000	3.25
LV048	46,200	13.95	58,600	4.65	48,400	16.35	39,300	3.40
LV060	59,100	13.60	77,800	4.80	61,600	15.80	53,400	3.75
LV060	64,000	13.30	72,800	4.40	66,400	15.00	50,800	3.40
Capacity and Efficiency Data - ECM Motor (Option)								
LV015	13,700	13.90	15,500	4.40	14,400	16.20	10,700	3.30
LV018	18,500	14.50	19,900	4.70	19,500	16.95	14,000	3.55
LV024	24,700	14.90	27,000	5.10	25,800	17.65	17,700	3.60
LV030	28,800	13.50	32,000	4.90	30,100	15.65	20,900	3.55
LV036	37,200	14.70	38,400	4.75	38,800	17.10	26,700	3.60
LV041	37,000	14.35	38,200	4.70	38,400	16.45	26,500	3.45
LV042	40,500	14.20	41,800	4.60	42,100	16.60	29,000	3.40
LV048	47,100	14.30	57,800	4.70	49,300	16.70	38,500	3.45
LV060	59,600	14.40	77,000	4.95	62,200	16.55	52,400	3.90
LV070	65,200	14.60	71,800	4.60	67,600	16.60	50,000	3.50

# About **Bosch**

## **Bosch Group**

The Bosch Group is a leading global supplier of technology and services in the areas of Automotive, Industrial Technology, Consumer Goods and Building Technology. The company was founded in Stuttgart, Germany, in 1886 and presently has more than 440 subsidiaries and is represented in over 150 countries.

In the U.S., Canada and Mexico, the Bosch Group manufactures and markets automotive original equipment and aftermarket solutions, industrial drives and control technology, power tools, security and communication systems, packaging technology, thermotechnology, household appliances and software solutions. The Bosch Group's products and services are designed to improving quality of life by providing innovative and beneficial solutions. In this way, the company offers technology worldwide that is "Invented for life." Additional information is available online at [boschheatingandcooling.com](http://boschheatingandcooling.com) and [bosch.ca](http://bosch.ca).

## **Bosch Thermotechnology in North America**

Bosch Thermotechnology is a leading source of high quality water heating and comfort systems. The company offers gas tankless, electric whole house and point-of-use water heaters, Bosch and Buderus floor-standing and wall mounted boilers, Bosch and FHP geothermal, water-source and air-source systems as well as controls and accessories for all product lines. Bosch Thermotechnology is committed to being Simply Smart by offering products that work together as integrated systems that enhance quality of life in an ultra-efficient and environmentally friendly manner. For more information, visit [boschheatingandcooling.com](http://boschheatingandcooling.com).

## **Bosch Water-Source Heat Pumps: Made in the U.S.A.**

Bosch and FHP water-source and geothermal heat pumps are made by highly trained and skilled workers in our factory based in Fort Lauderdale, Florida. They are manufactured with rigorous standards and factory testing ensuring high efficient operation over the life of the unit. Bosch's ISO 9001 and ISO 14001 certified facilities provide consistent quality in every unit built.



Heating



Cooling



Hot Water



Controls

### **Bosch Thermotechnology Corp.**

Watertown, MA • Londonderry, NH • Ft. Lauderdale, FL  
General Inquiries: 1-866-642-3198

Copyright © 2019 Bosch Thermotechnology Corp.  
All rights reserved. Subject to change without notice.